

# WS-855GS

15" IP 64 Waterproof Workstation: Robust, Shock Resistance



## Features

- Die-cast aluminum front panel with integrated LCD screen
- New robust chassis and retention kit structure for shock and vibration
- Front panel, membrane keys, mouse pad and drive-bay enclosure meet IP 64 standard for tough environment
- Full function membrane keys and submerged OSD controller
- Advanced thermal and air-flow design
- Analog VGA interface supports all CPU boards

## Specifications

Model	WS-855GS
LCD Size	15"
Resolution	1024 x 768
Brightness (cd/m <sup>2</sup> )	450
Contrast	800:1
LCD color	16.2M
Backlight Hours	70000 (LED Backlight)
Input Interface	Analog VGA (DB-15)
Slot	10 slots / MB
Form Factor	Full/Half-size SBC / microATX motherboard
Mounting	19" rack mount
Rack Height	8U
Front Frame	Aluminum
IP Level	IP 64
KeyPad	59 Keys
Function Key	10 Keys
Touch Pad	Yes
Front Panel USB	2
HDD Drive Bay	1 x 3.5" HDD
CD-ROM Drive Bay	1 x 5.25" CD-ROM
FDD Bay	1 x 3.5" FDD
System Fan	12cm ball bearing 99.6 CFM fan
Touch Screen	5-wire resistive touch screen
Vibration	5 ~ 17 Hz, 0.1" double amplitude displacement / 17~640 Hz, 1.5G acceleration peak to peak
Shock	10G acceleration peak to peak (11ms)
Relative Humidity	10%~95%, non-condensing
Operating Temperature	0°C ~ 50°C
Storage Temperature	-10°C ~ 60°C
Color	Silver (Pantone PMS-8001)
Dimensions (W x H x D) (mm)	483 x 353 x 261
Weight (NW / GW)	12 kg / 18.2 kg
Recommended Backplane	AT: BP-10S ATX: PCI-10S2, HPE-7S1/8S, PE-6S/7S/7S2/8S/9S AT/ATX: PCI-10S, IP-10S, IPX-9S
Recommended microATX MB	IMB-9454, IMB-G41A
Power Supply	AT: ACE-925A(AP-U)-RS, ACE-932A-RS, ACE-935AL-RS, ACE-T140A-RS ATX: ACE-4860AP-R11-RS, ACE-828A(A/M/V)-RS, ACE-A130B-R10, ACE-A140A-R10, ACE-A140A-S-R10, ACE-A160A-R10

1

IEIMobile Solutions

2

Automation Panel Solutions

3

Healthcare Panel PC Solution

4

Industrial System

5

ORing Network Communication

6

Automation Control

7

Optional Peripherals

## Ordering Information

Part No.	Description
WS-855GS/A130B/R-R40	8U 15" 400cd/m <sup>2</sup> XGA LCD 10-slot industrial workstation with ACE-A130B-R10 300W ATX with PFC power supply and 15" resistive touch screen, R40
WS-855GSATX/A130B/R-R40	8U m-ATX 15" 400cd/m <sup>2</sup> XGA LCD workstation with ACE-A130B-R10 300W ATX with PFC power supply and 15" resistive touch screen, M-ATX version, R40

## Packing List

Part Number	Description	Amount	Remark
32000-000002-RS	AC Power Cable	1	Standard Packing, for Europe, 32000-000004-RS for South Africa 32000-000022-RS for Australia, 32000-000025-RS for America 32000-000026-RS for Switzerland
32000-101200-RS	VGA Cable	1	A)D-SUB 15P MALE 90°(B)D-SUB 15PIN MALE
32100-034801-RS	PS_ON Cable for ATX signal	1	
41015-0003C0-00-RS	Press Stick Kit (Long)	4	
41015-0004C0-00-RS	Press Stick Kit (Short)	3	
47001-000101-RS	Press Stick Rubber	7	
	User Manual	1	
32000-075000-RS	KeyPad / MousePad PS/2 Cable	1	For SBC Models
32000-078400-RS	KeyPad / MousePad PS/2 Cable	1	For m-ATX (Motherboards) Models
32000-101100-RS	RS-232 Cable / Touch Pen / Driver CD-ROM for Touch Screen	1	(A)D-SUB 9P MALE 90°(B)D-SUB 9PIN FEMALE

## Full function membrane keys & submerged OSD controller with Touch pad

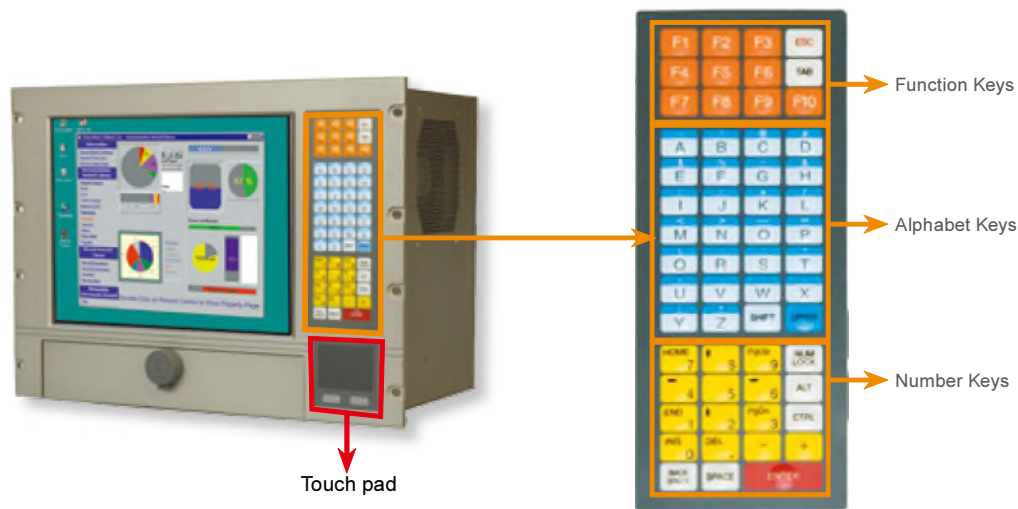

## Dimensions (Unit: mm)

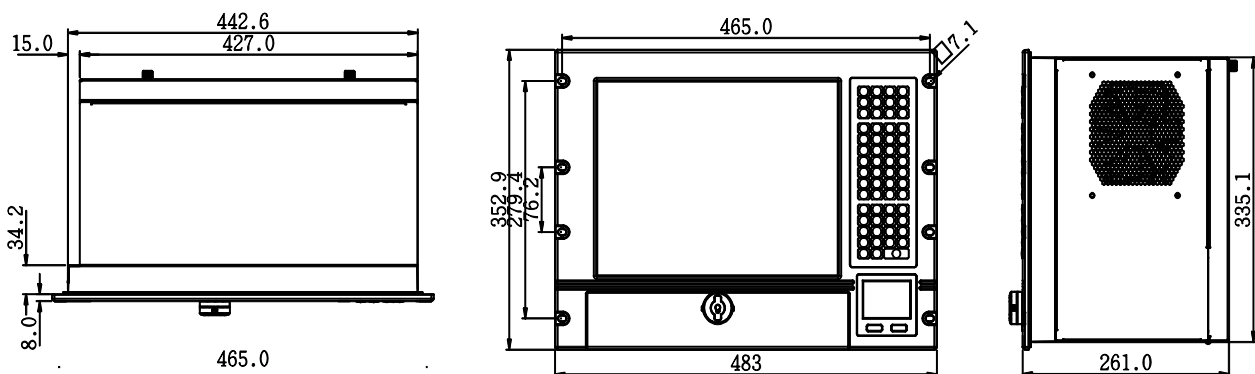

1

IEIMobile  
Solutions

2

Automation  
Panel  
Solutions

3

Healthcare  
Panel PC  
Solution

4

Industrial  
System

5

ORing  
Network  
Communication

6

Automation  
Control

7

Optional  
Peripherals