

AFL-F08A 8" Flat-bezel Panel PC

The new 8" panel is a full-flat surface touchscreen PC. The AFL-F08A includes all necessary input/output interfaces to control any subsystem or automation hardware in your office, business, or home. The new stylish design is easily integrated into any environment. The front panel is IP 64 compliant. An optional projected capacitive touchscreen provides a multi-touch interactive user experience.

Features:

- 8.0" LED TFT LCD with stylish flat-bezel touchscreen
- Optional projected capacitive touchscreen supports multi-touch
- Fanless system with Intel® Atom™ N270 processor (512K Cache, 1.60 GHz, 533 MHz FSB)
- Hot keys controlled by cap-sensor in the front panel
- Optional color change kit matches the style of any decoration
- Wireless LAN 802.11b/g/n
- Built-in 2-megapixel CMOS camera with low-light capability
- Two 1.5W speakers and microphone for multimedia applications
- IP 64 compliant front panel
- IEI One Key Recovery solution allows you to create rapid OS backup and recovery (suggest with over 4GB storage capacity)



Full-flat Surface Touchscreen

The AFL-F08A flat-bezel design covers the entire front frame (bezel) of standard LCD to make the screen and bezel appear to blend together. The seamless flat-bezel touchscreen system offers a stylish and easy to clean surface.

Flat-bezel Advantages:

- Better visual effects
- No edge effect
- Sleek and stylish
- Easy to clean

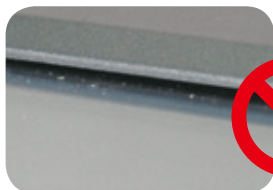

With Bezel



Applications:



OFFICE



LIVING ROOM



YACHTING



KITCHEN



AUTOMATION

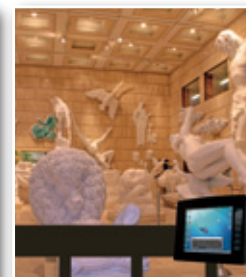

MUSEUM

Picture Frame In-Wall Mount

This optional kit includes a decorative front plate and wall mount enclosure to securely house the AFL-F08A panel PC. The enclosure includes knockouts for power and I/O interface cables.



3.7mm

Decorative front plate
In-Wall Enclosure

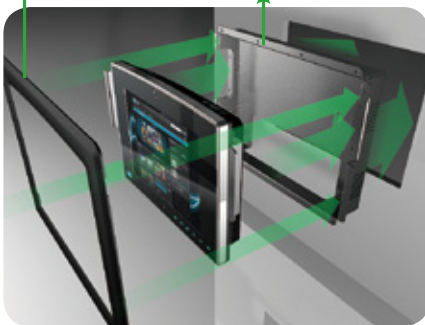

• Optional Decorative Kit:

DIM.
300mm x 230mm x 3.7mm

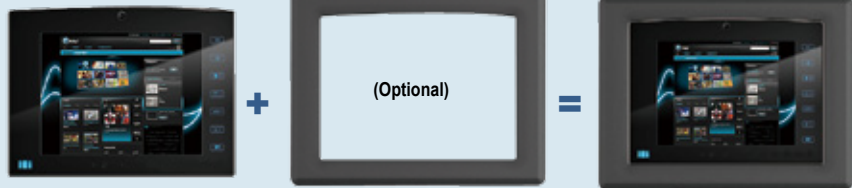

■ Projected Capacitive Touch Sensor

• Operational Theory

Projected capacitive touch is based on principle of embedding an array of micro-fine sensing wires within a multi-layer laminated screen behind a protective front surface, ensuring that the sensing medium is well-protected from accidental damage.



Activated by a finger or gloved hand

• Windows® 7 with Multi-touch Capability

The AFL-F08A comes with the true multi-touch Microsoft Windows 7 operating system. Windows 7 features improved touch and gesture support. With Windows 7, handwriting recognition is faster, more accurate and with more language support.

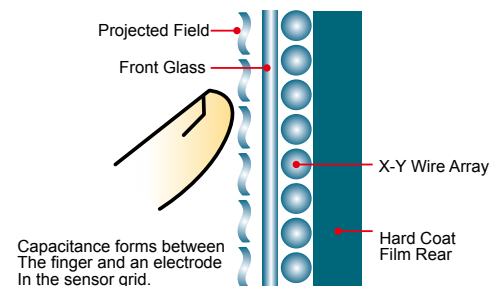

• 7H Anti-scratch Surface (Projected capacitive type touch screen)

Projected Capacitive touch technology utilizes a durable glass front surface. 7H hardness is stronger than the conventional touch panel and therefore is able to protect the screen from damage.

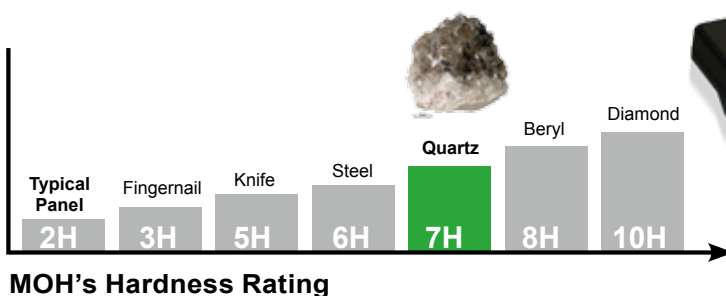

Hot Keys Controlled by Cap-Sensor

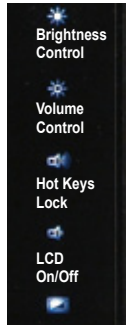

Versatile I/O Ports

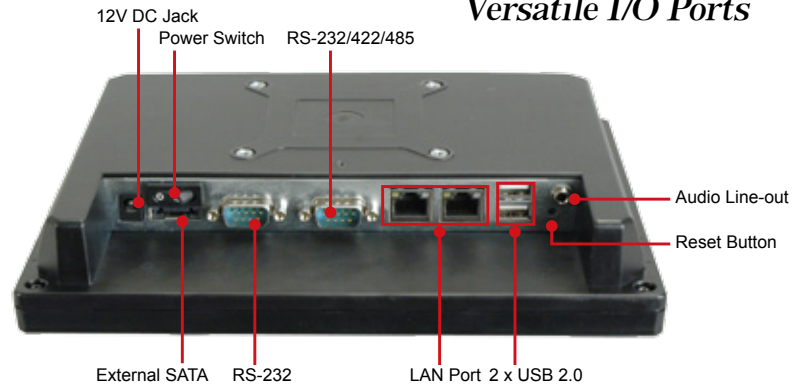

AFL-F08A
Dimensions (Unit: mm)

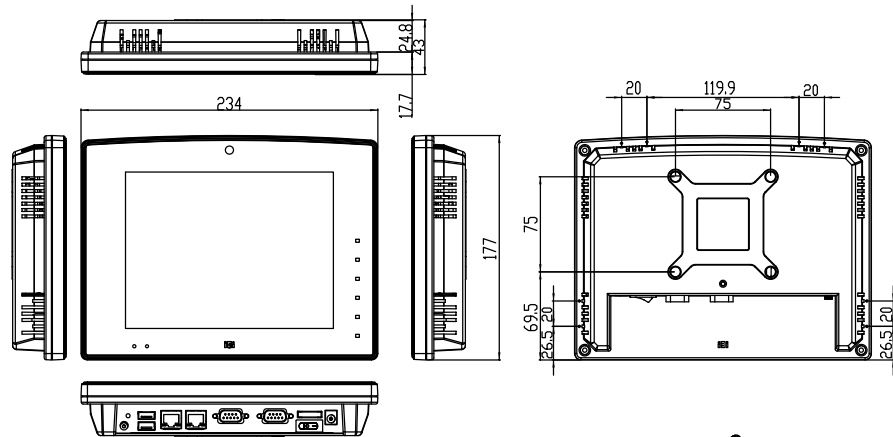

Decoration Kit
Dimensions (Unit: mm)

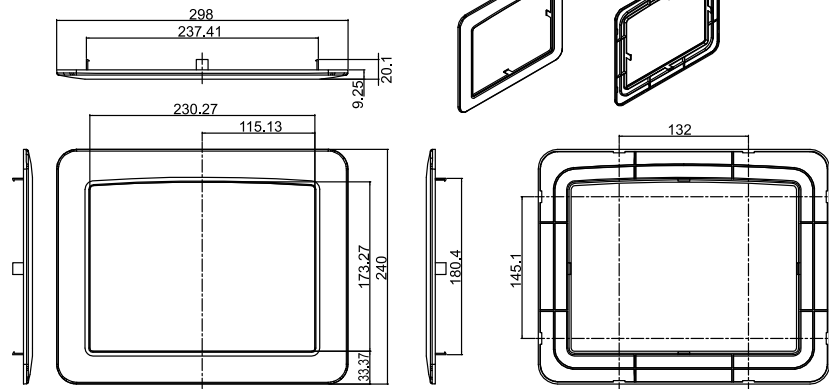

In-Wall Cage
Dimensions (Unit: mm)

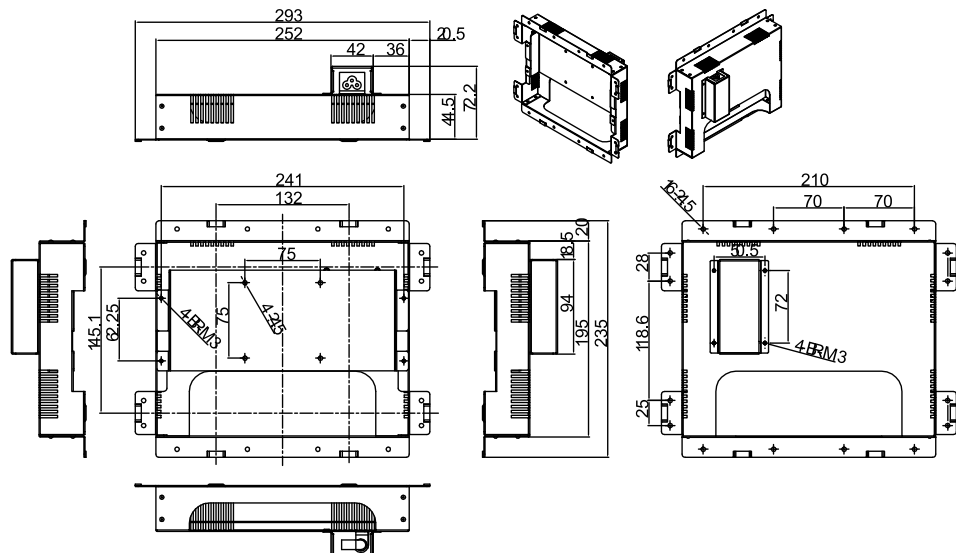

Specifications

Model	AFL-F08A-N270	
LCD Size	8"	
Max Resolution	800 x 600	
Brightness (cd/m ²)	250	
Contrast Ratio	500:1	
LCD Color	262K	
Pixel Pitch (mm)	0.2025 (H) x 0.2025 (V)	
Viewing Angle (H-V)	140° / 130°	
Backlight MTBF	30000 hrs (LED Backlight)	
SBC Model	AFLMB-945GSE-N270-R10	
CPU	Intel® Atom™ Processor N270 (512K Cache, 1.60 GHz, 533 MHz FSB)	
Chipset	Intel® 945GSE + ICH7M	
RAM	Supports one 400MHz or 533MHz DDR2 SO-DIMM (Max. 2GB)	
I/O Ports	1 x RS-232 COM Port 1 x RS-232/422/485 COM Port 2 x RJ-45 for GbE 2 x USB 2.0	1 x Reset Button 1 x Audio Port (line-out) 1 x 12V DC Power Jack 1 x External SATA
SSD	CF Type II	
Watchdog Timer	Software programmable supports 1~255 sec. system reset	
Audio	AMP 1.5W + 1.5W (internal speakers)	
Wireless Connection	1 x Wireless LAN 802.11b/g/n Module (internal PCIe Mini interface)	
Camera	2 megapixel with Low Light Function and digital microphone	
Front Panel Construction	ABS + PC Plastic front frame	
Membrane Keypad	LCD on/off, Brightness up/down, Volume up/down by cap-sensor	
Mounting	In-Wall, Panel, Wall, Stand and Arm VESA 75mm x 75mm	
Front Panel Color	Black	
Dimensions (WxHxD) (mm)	234 x 177 x 43	
Operation Temperature (°C)	-10°C ~ 50°C	
Storage Temperature (°C)	-20°C ~ 60°C	
N/G Weight	1.8Kg	
IP Level	IP 64 compliant front panel	
Safety & EMC	CE / FCC	
Touch Screen	5 (touch controller IC is on board) or projected capacitive type touch screen	
Power Adapter	63000-FSP036RAB608-RS 36W Power Adapter (Meet PSE) Input: 90VAC~264VAC, 50/60Hz Output: 12VDC	
Power Requirement	12VDC	
Power Consumption	32W	



Ordering Information

	Part Number	Description
Resistive Touch Panel	AFL-F08A-N270/R/1G-R25	8.0" 250cd/m ² SVGA fanless panel PC with Intel® Atom™ N270 1.6GHz CPU, 1GB DDR2 RAM, 802.11b/g/n Wi-Fi, touch screen, 2 megapixel camera, microphone, R25
Projected Capacitive Multi-Touch Panel	AFL-F08A-N270/PC/1G-R25	8.0" 250cd/m ² SVGA fanless panel PC with Intel® Atom™ N270 1.6GHz CPU, 1GB DDR2 RAM, 802.11b/g/n Wi-Fi, projected capacitive multi-touch panel screen, 2 megapixel camera, microphone, R25

Options

Item	AFL-F08A-N270/R (Resistive type touch)	AFL-F08A-N270/PC (PCT type touch)
Panel Mounting Kit	AFLPK-12	
Wall Mounting Kit	AFLWK-12	
Rack Mounting Kit	AFLRK-08	
Arm	ARM-11-RS / ARM-31-RS	
Stand	STAND-100-RS / STAND-C12	
VSTAND	VSTAND-A10-R11	
9~30VDC to 12VDC converter Module	IDD-930160-KIT	
OS: Win CE 6.0 (128 MB CF card)	AFLCF-F08-N270-CE060-R24	
OS: Win XPE (1 GB CF card)	AFLCF-F08-N270-XPE-R24	
OS: Win 7 Embedded (4 GB CF card)	AFLCF-F08-N270-WES7E-R24	AFLCF-F08-N270-WES7P-R24
Magnetic Stripe Reader	AFLP-08AMSR-U	
DC 12V Input UPS	AUPS-A10-R10 (7.4V 3800mAH)	
DC 9~36V Input UPS	AUPS-A20-R10 (7.4V 3800mAH)	
In-wall Cage	AFLIWC-F08A-R10	
Bluetooth V2.0+EDR	AFL-BT-KIT02-R10	

Note: Multi-touch function is only supported on Windows 7 on PCT type touch.

Packing List

Item	Part Number	Q'ty	Specification
Screw Pack	44013-030041-RS	4	M3;5mm
Power Adpater	63000-FSP036RAB608-RS	1	90~264V AC; 12V DC; 36W (Meet PSE)
Power Cord	32000-000002-RS	1	1750mm; European Standard (EU or US, depending on the shipment country)
Utility CD	7B000-000087-RS	1	
Touch Pen	43125-0002C0-00-RS	1	
One Key Recovery CD		1	